

Meeting will start 12:05 CT



**AEE Middle Tennessee – May Chapter Meeting Updates**



Association of Energy Engineers

# AEE Middle TN – May Chapter Meeting Updates

## Upcoming Meetings

- 6/11 – June Chapter Meeting (Hybrid)
  - 12-1 PM @ UT CIS and on Microsoft Teams
  - TOWT Modeling: M&V Analysis with Power Takeoff
- ~6/15 – Officer Nomination Form Sent Out
- 7/15 [Tentative] – Elections & Whiskey Tasting Networking
  - 5:30 to 6:00 PM – Chapter Officer Elections
  - 6:00 to 7:00 PM – Whiskey Tasting & Networking
    - *Working to finalize event details and catering ASAP*
  - @ Sesco Lighting, 636 Grassmere Park Suite 105, Nashville
- **8/6: 2026 Gary Moody Memorial Golf Scholarship Scramble**
  - More on next slide
- 9/16-9/18: AEE World Orlando – No Chapter
- 10/15 – October Chapter Meeting, In-Person

# 2026 Gary Moody Memorial Scholarship Golf Scramble



## MOODY GOLF SCRAMBLE

The Gary Moody Scholarship Golf Scramble has raised over \$22,000 in scholarships for students in energy-related fields of study at Tennessee Tech since its creation in 2017. As the chapter continues to provide excellent educational programs for the professional community, we also contribute to the future of our industry through financial scholarships to deserving students. The goal of AEE is to foster cooperative action in advancing the common purposes of its members and to promote activities designed to enable the industry to be conducted with the greatest economy and efficiency.

The Scramble is run in honor of Gary Moody who was an AEE member, beloved member of the Tennessee energy community from his time spent working with Piedmont gas, and a great father, friend, man.



2026 Tournament Date: Thursday, August 6<sup>th</sup>, 2026  
*Hosted at Pine Creek Golf Course*

## Pricing goes up at the end of May!!

- Teams: \$800

Last Minute Pricing, June – July:

- Teams: \$840



## Sponsorship Opportunities Remain

- Silver Hole Sponsor: \$200
- Drink Cart Sponsor: \$300, 1 remaining
- Gold Booth Sponsor: \$500

# AEE Middle TN – May Chapter Meeting Updates

## Help Wanted – Board Opportunities Available

*Please help share with colleagues who may be interested*

- Elected Officer Openings
  - Secretary
- Appointed Board Openings
  - Membership Director
  - Media Director
  - CWEEL Director
  - Industry Liaisons (Multiple Openings, e.g. Utility Liaison, Manufacturing Liaison, Commercial Building Liaison)
- **Elections for 2026/2027 Term will be in July**
  - Nomination form to be sent out in June

## Role Descriptions

- Secretary (Elected)
  - Meeting Management: Records minutes for board and chapter meetings, tracks attendance and awards PDH information
  - *Record Custodian: Bylaws expert + membership lists\**
  - *Communication: Schedules and shares meeting info\**
- Membership Director (Appointed)
  - Maintains member list, outreach to new members, growing the chapter sustainably
- Media Director (Appointed)
  - Manages StarChapter and LinkedIn + communications
- Industry Liaisons (Appointed)
  - Ensures that chapter meeting topics cover areas of interest to industry being represented
  - Supports membership recruiting for respective industries

*\*In absence of membership / media director*

# Q-PAC

## Fan Technology Review

# PRESENTER INTRO

- MSc in Mechanical Engineering
- Professional Engineer
- Sales and Applications Engineer
- Past Chair of ASHRAE TC 5.5: Air-to-Air Energy Recovery Equipment
- Voting Member of ASHRAE TC 5.1: Fans
- Member of ASHRAE Standard 62.1: Ventilation Committee
- ASHRAE British Columbia Past President



# U.S. ENERGY CONSUMPTION

Where do buildings — and fans — fit in the national picture?

**~37%**

of ALL U.S. primary energy  
consumed by buildings

*Residential + Commercial combined*

Energy consumed in buildings include HVAC, Lighting,  
Computers, etc.

*254 billion kWh for A/C; largest single end-use*

Commercial sector alone

*40–50% of commercial energy = HVAC systems*

*Source: EIA Monthly Energy Review, April 2024*

U.S. Primary Energy by Sector (2023)

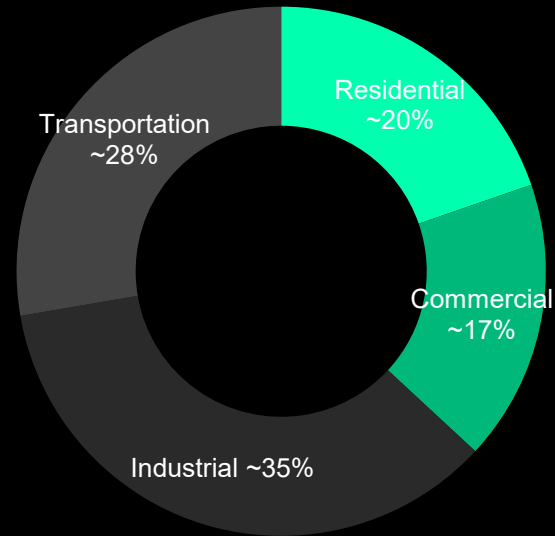

# Fan Energy: The Scale of the Opportunity

**\$500B+**

Spent annually on energy  
in U.S. buildings

*Residential + commercial combined*

**~15%**

Of all building energy  
consumed by fans

*DOE / HPAC Engineering estimate*

**30–50%**

Of HVAC energy alone  
is fan energy

*Especially in constant-volume systems*

## COMMERCIAL BUILDING ENERGY END-USE BREAKDOWN

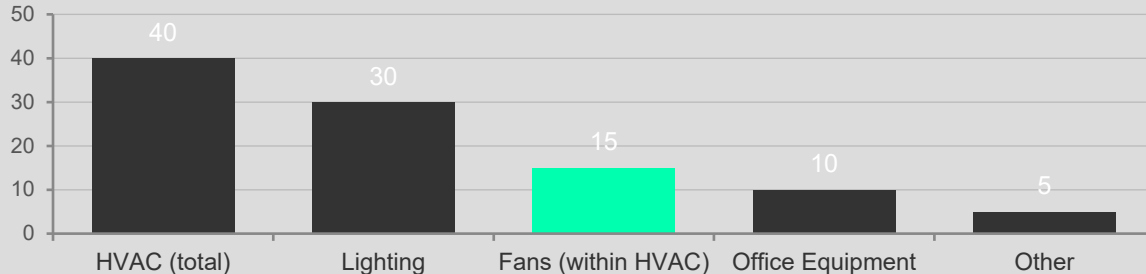

## Why fans are the leverage point

- Fans usually run continuously — unlike chillers or boilers
- In some applications, fans run at constant volume (CAV)
- Using higher efficiency fan results in large savings in building energy consumption

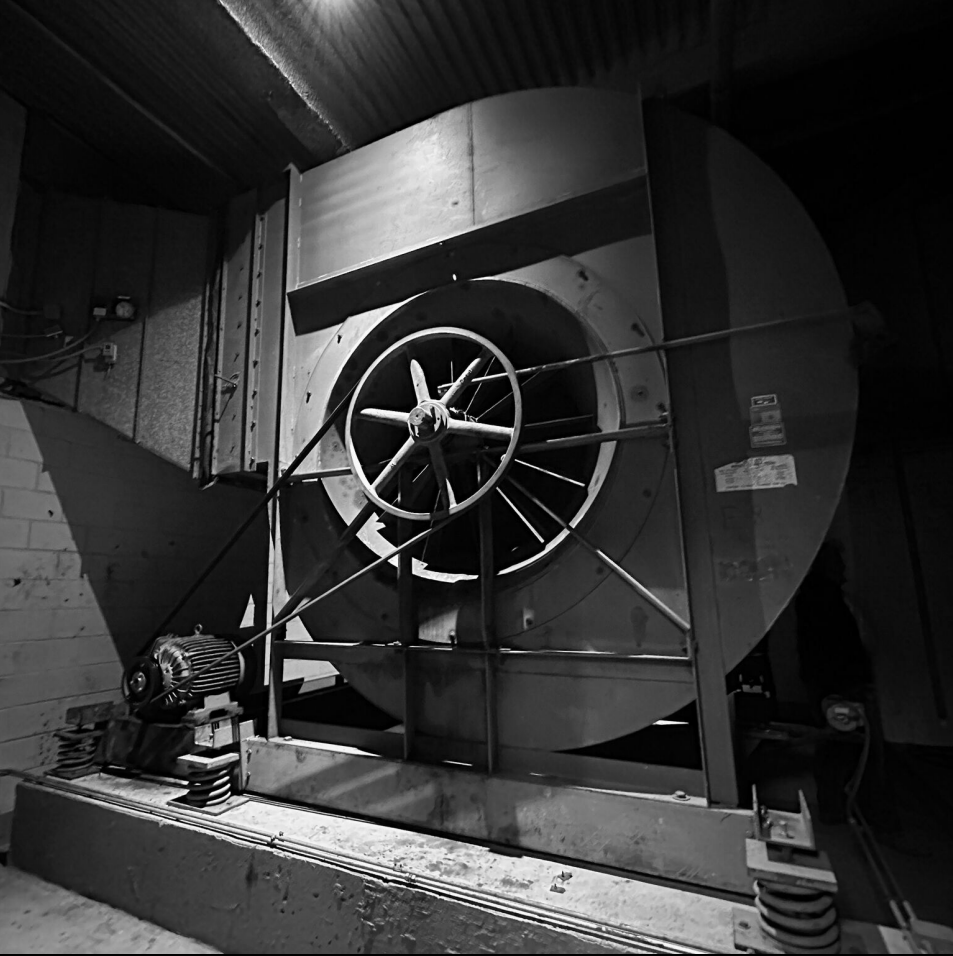

# Fans Components

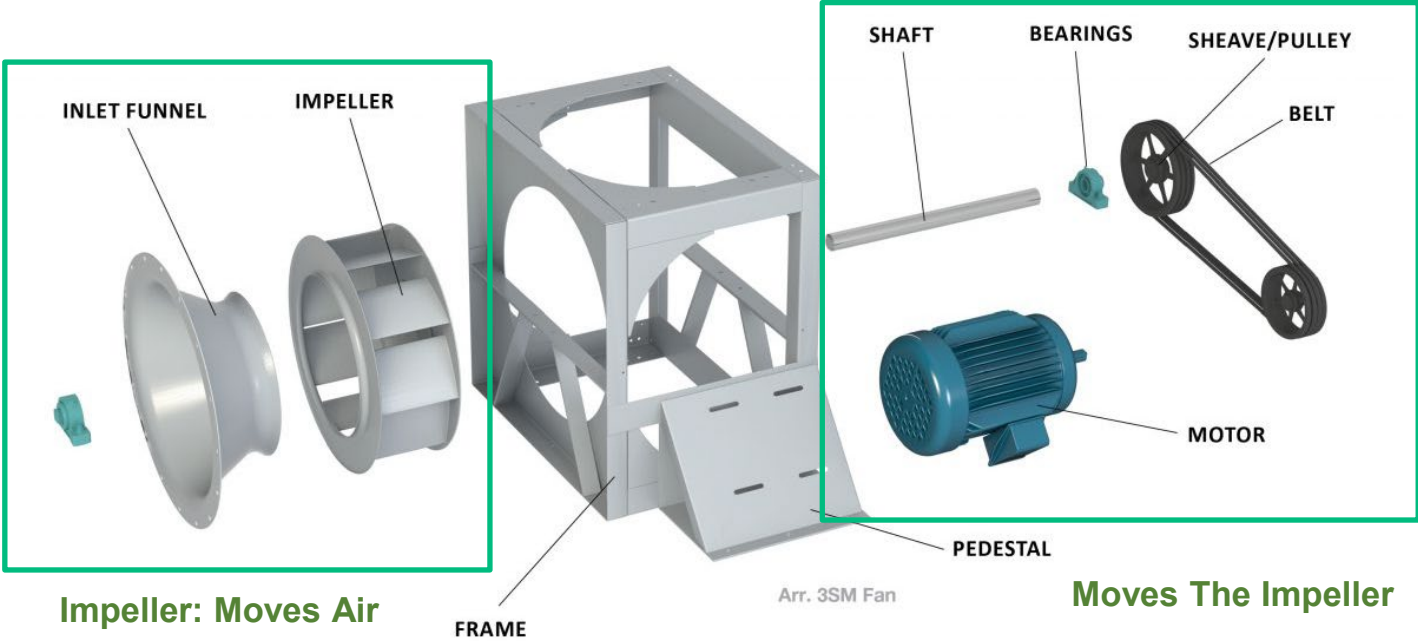

# Fans: Impellers

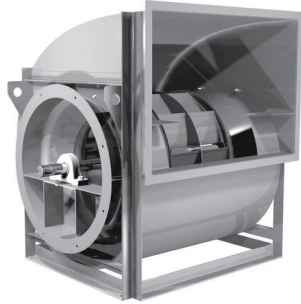

- Impellers are devices that create air movement
- Come in different shapes depending on the application
- Impeller design has major impact on fan aerodynamic efficiency

# Advanced Impeller Designs



# Fans: Electric Motors

- AC induction motors
- Used in industry for over a century
- Simple construction and maintenance
- Good efficiency at peak load
- Constant speed at constant frequency
- Requires an external device to modulate speed

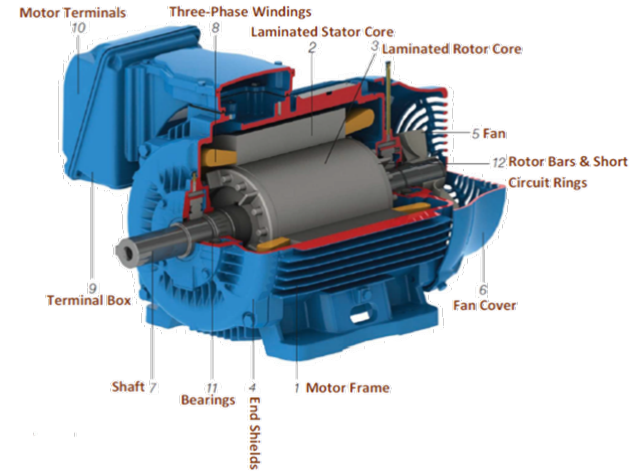

# Fans: Electric Motors

- ECM: Electronically Commutated Motor
- History in 1960's locomotive motors
- DC Native Motor (incoming AC is rectified to DC)
- Utilize Permanent Magnets
- Integrated variable speed motor

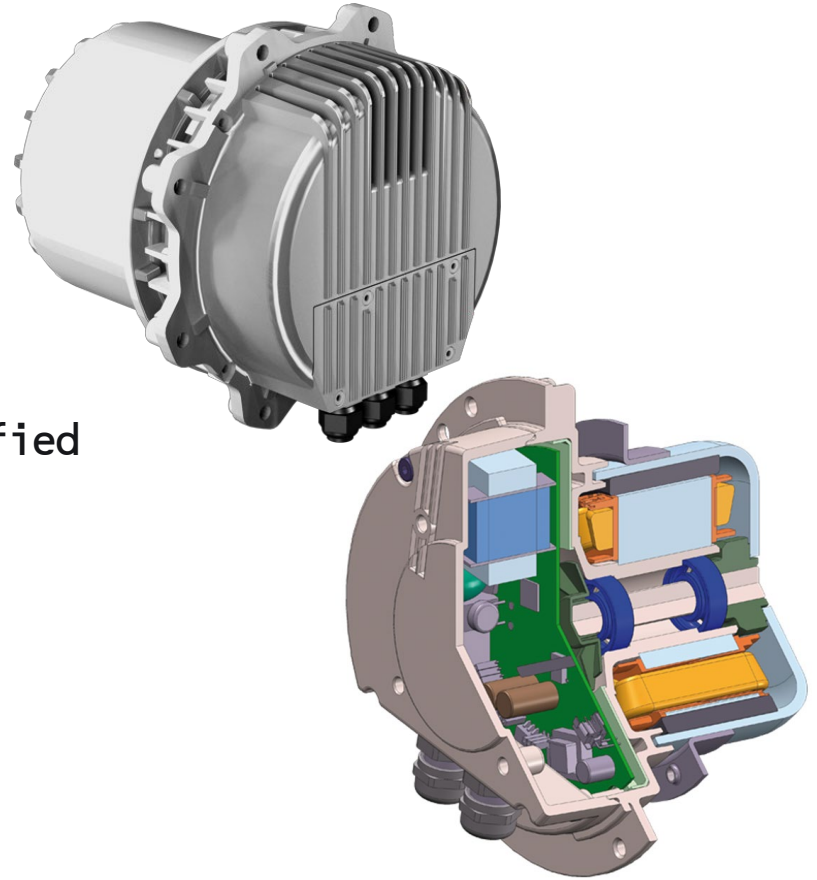

# Fan Speed Modulation

Modulating fan speed with a VFD or EC motor reduces power by the cube of the speed ratio

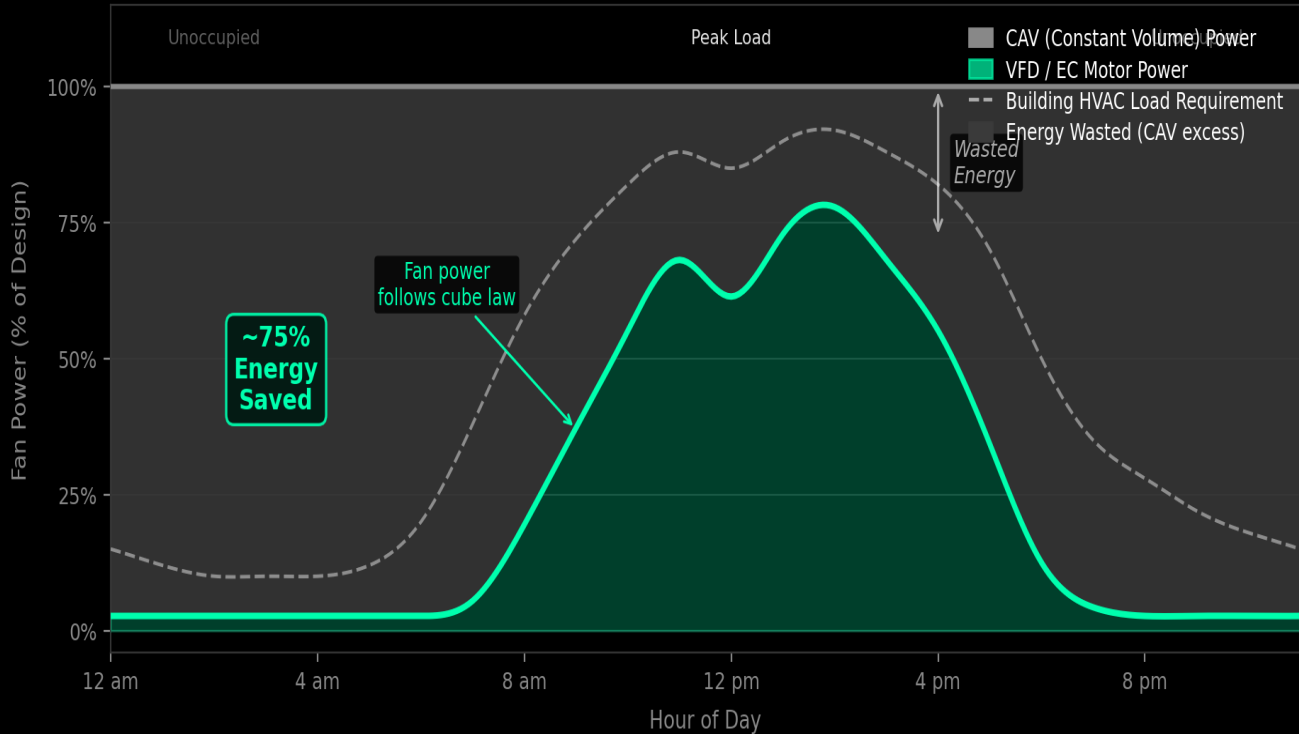

- HVAC load is not constant throughout day
- Fan speed must modulate to reduce energy consumption at partload

# Fan Speed Modulation: History

Modulating fan speed with a VFD or EC motor reduces power by the cube of the speed ratio

---

- Prior to 1980's most buildings (including large commercial buildings) were designed with CAV fan systems
- Only in 2010, ASHRAE 90.1 started requiring fan speed modulation for certain applications and motor sizes
- DOE issued a positive determination that Standard 90.1-2016 would achieve greater energy efficiency and notified states they should adopt 90.1-2016 or equivalent by February 2020
- Some states are just now enforcing ASHRAE 90.1 2010 as the building energy efficiency baseline

# VARIABLE FREQUENCY DRIVES

How a VFD controls AC induction motor speed — and why nothing else can

## THE PROBLEM

- AC induction motors run at a speed set by supply frequency — fixed at 60 Hz
- Without a VFD, the only control options are dampers or throttling — both wasteful
- Dampers waste energy by fighting the fan, not slowing it

## THE VFD SOLUTION

- Converts fixed 60 Hz AC → DC → variable frequency AC
- Output frequency 0–60 Hz → continuously variable motor speed
- Speed follows load demand → cube law savings apply

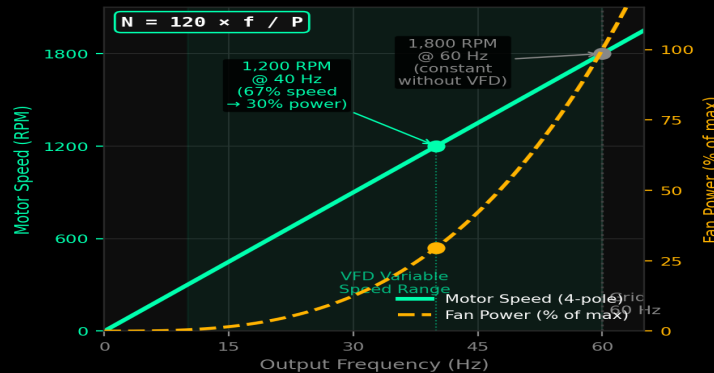
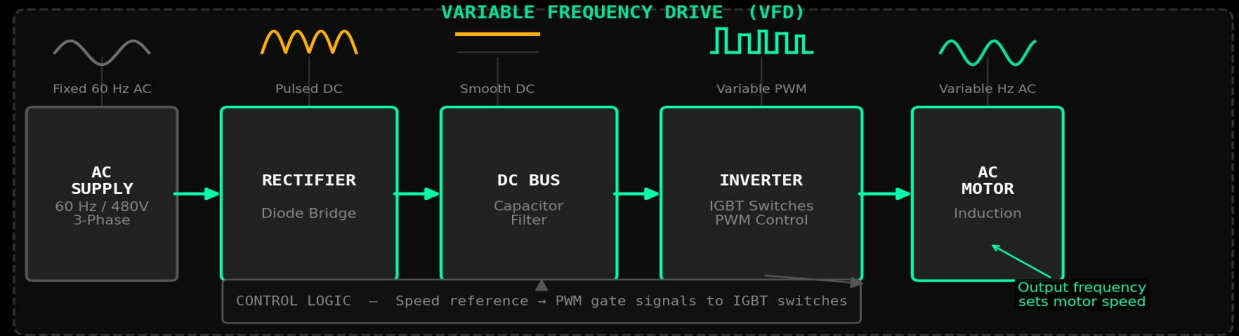

## SPEED EQUATION

$$N = 120 \times f / P$$

$N$  = Synchronous speed (RPM)

$f$  = Frequency (Hz)

$P$  = Number of poles

4-pole @ 60 Hz = 1,800 RPM

# VARIABLE FREQUENCY DRIVES

---

EC Motors come with integrated  
speed modulation and do not  
need VFD's

*4-pole @ 60 Hz = 1,800 RPM*

**Q-PAC**

# Introduction of Fan Arrays

## Pros:

- ⓧ Redundancy
- ⓧ Installable in less accessible locations
- ⓧ Smaller footprint

## Cons:

- ⓧ Complicated install
- ⓧ Complicated operation and controls
- ⓧ Compromise on efficiency



# MULTIMOTOR PLENUM FAN (MPF)

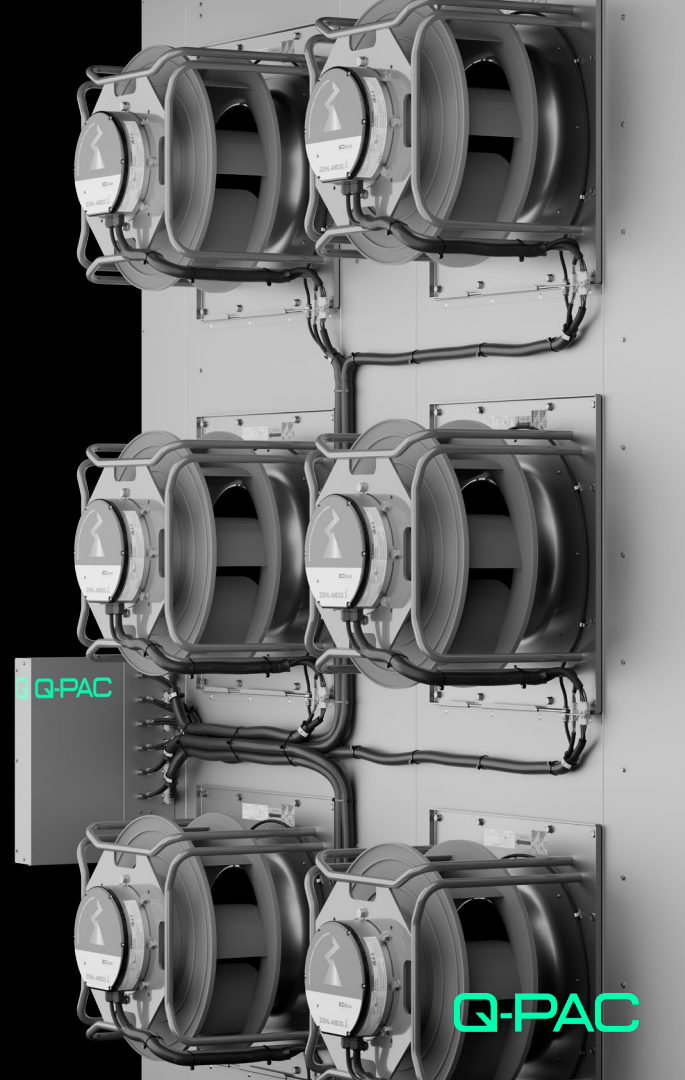

# MULTIMOTOR PLENUM FAN (MPF)

MPFs merge the simplicity of traditional single-motor blowers with the redundancy of fan arrays—eliminating the complexity, skilled labor requirements, and high maintenance costs associated with legacy commercial HVAC fans.

## FEATURES

- Multiple motors operating in unison
- Single point of power and control
- Unique, tested performance profile
- Simple motor replacement

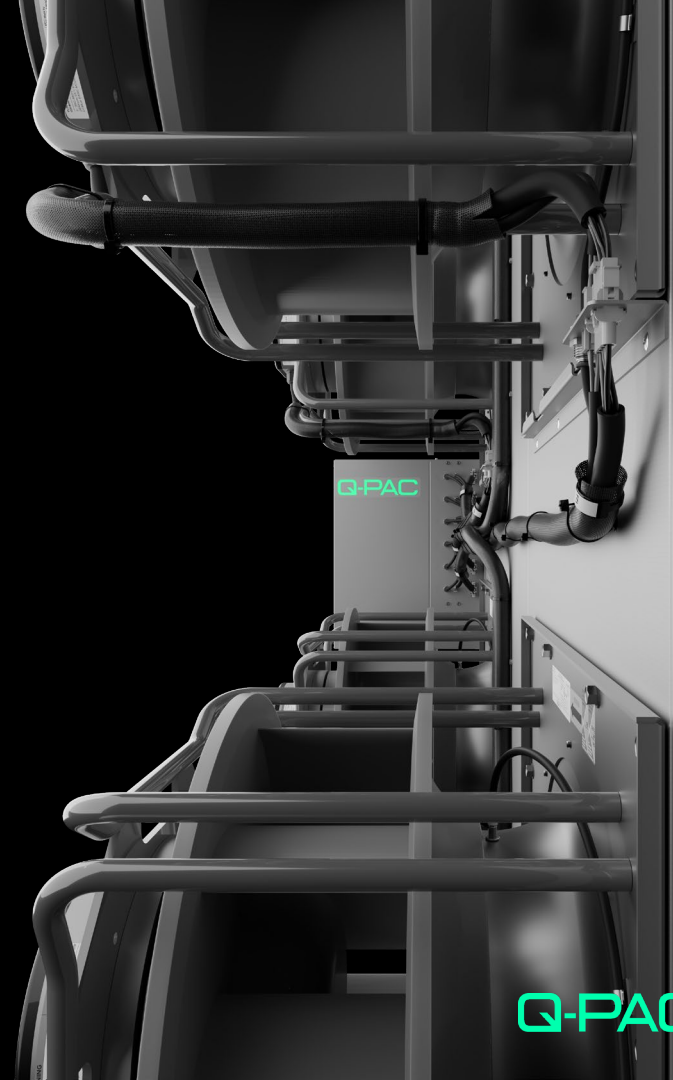

# KNOCKDOWN FAN

Q-PAC's MPF ships knockdown for field assembly. Each knockdown kit includes:

1. Frame panels and assembly hardware
2. Fan Controller
3. Plug Fans
4. Control Panel (optional accessory)
5. Assembly guide, user manual, and quick start wiring guide (not shown)

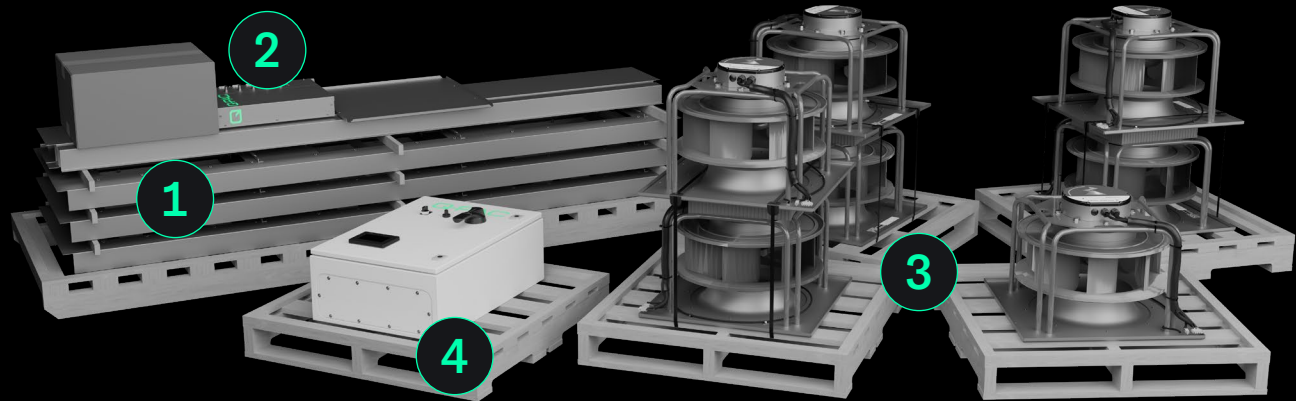

# FAN COMPONENTS

1. Patented Fan Controller
2. Fan Frame
3. Plug Fan (Motorized Impeller)
4. Frame Harnesses

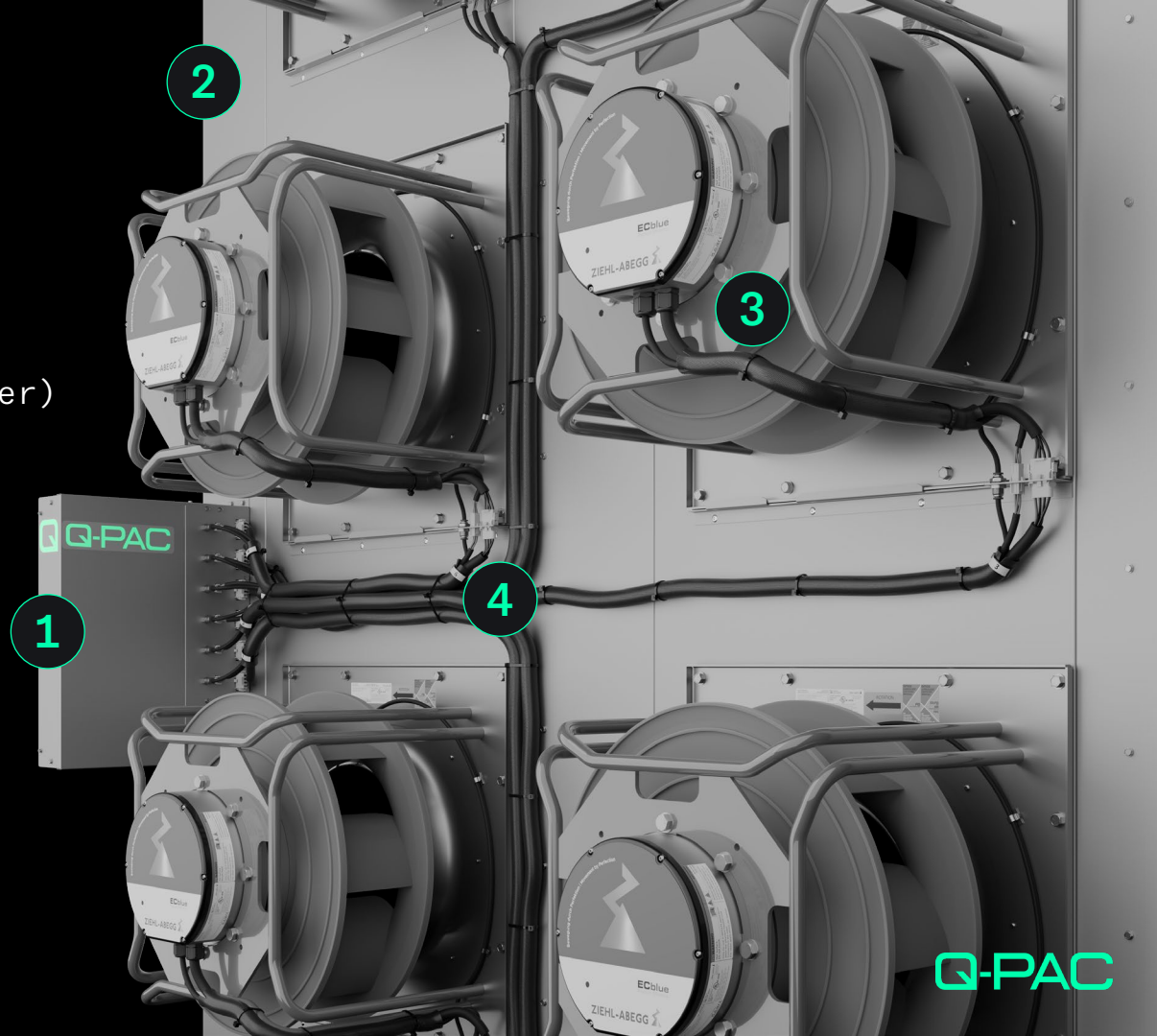

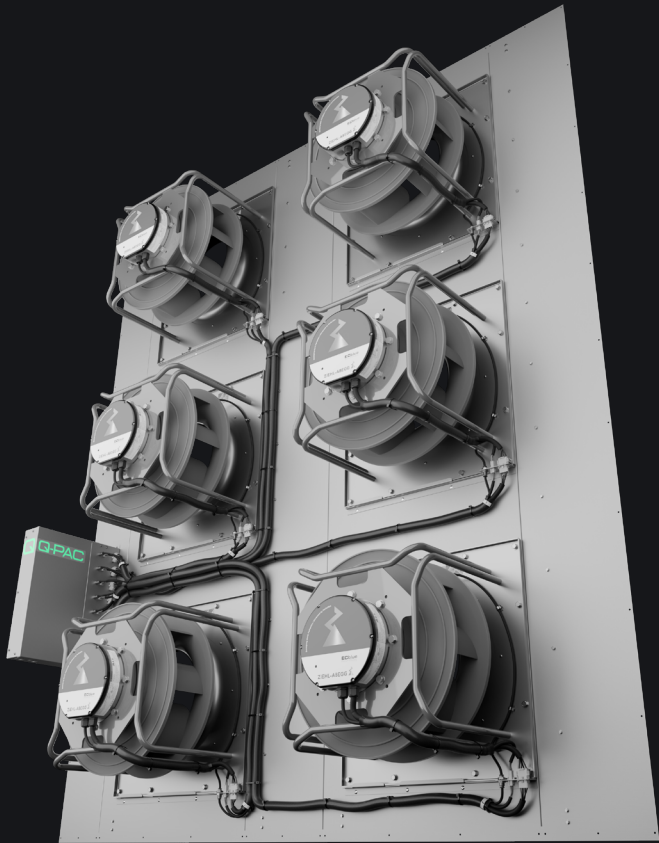

# Q-PAC Fan Energy Savings Case Studies

## Case Study 1: Pennsylvania Liquor Board Building

Two AHU's from 1930's, One had a catastrophic fan failure

Opportunity to compare existing fan power consumption with Q-PAC



# Power Consumption Data

## Power Consumption Data

FAN TYPE	POWER CONSUMPTION (W)
Q-PAC MPF Supply Fan (AC-2)	10,784.16 W
Conventional Supply Fan (AC-1)	19,078.15 W
Return Fan with VFD (AC-2)	3,655.83 W
Return Fan without VFD (AC-1)	3,999.19 W

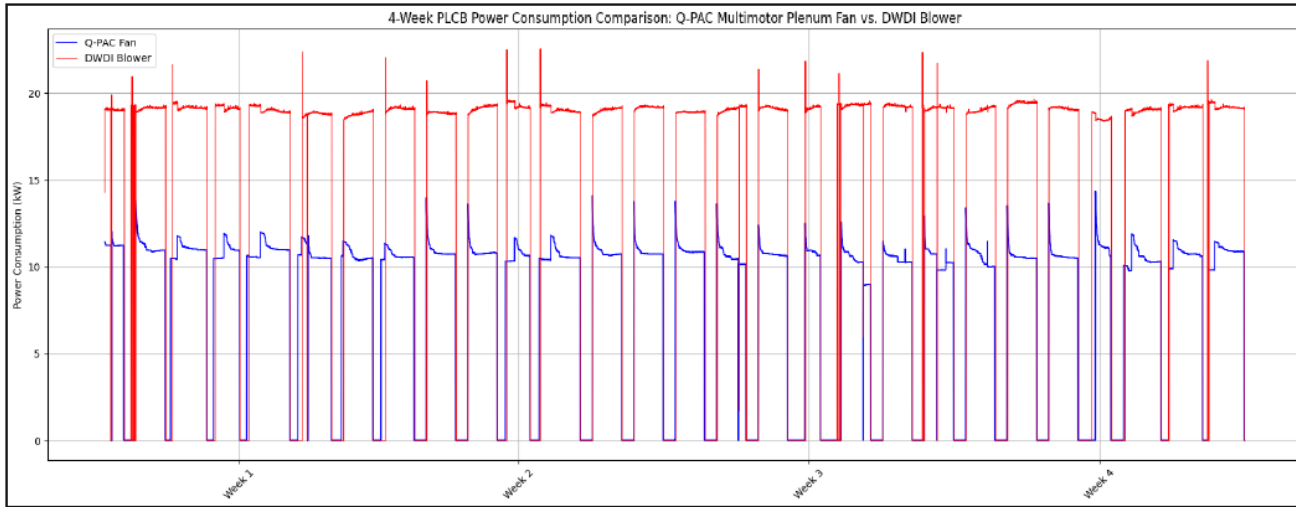

# Power Consumption Data

30,000 CFM flow rate at max load  
Over \$8000 annual energy savings  
Less than 3 years ROI

TOTAL SAVINGS

45%

# Q-PAC Fan Energy Savings Case Studies

Case Study 2: Commercial Plaza (Nationwide Bldg)

Plus 1 million square feet  
47 fan arrays



# Power Consumption Data

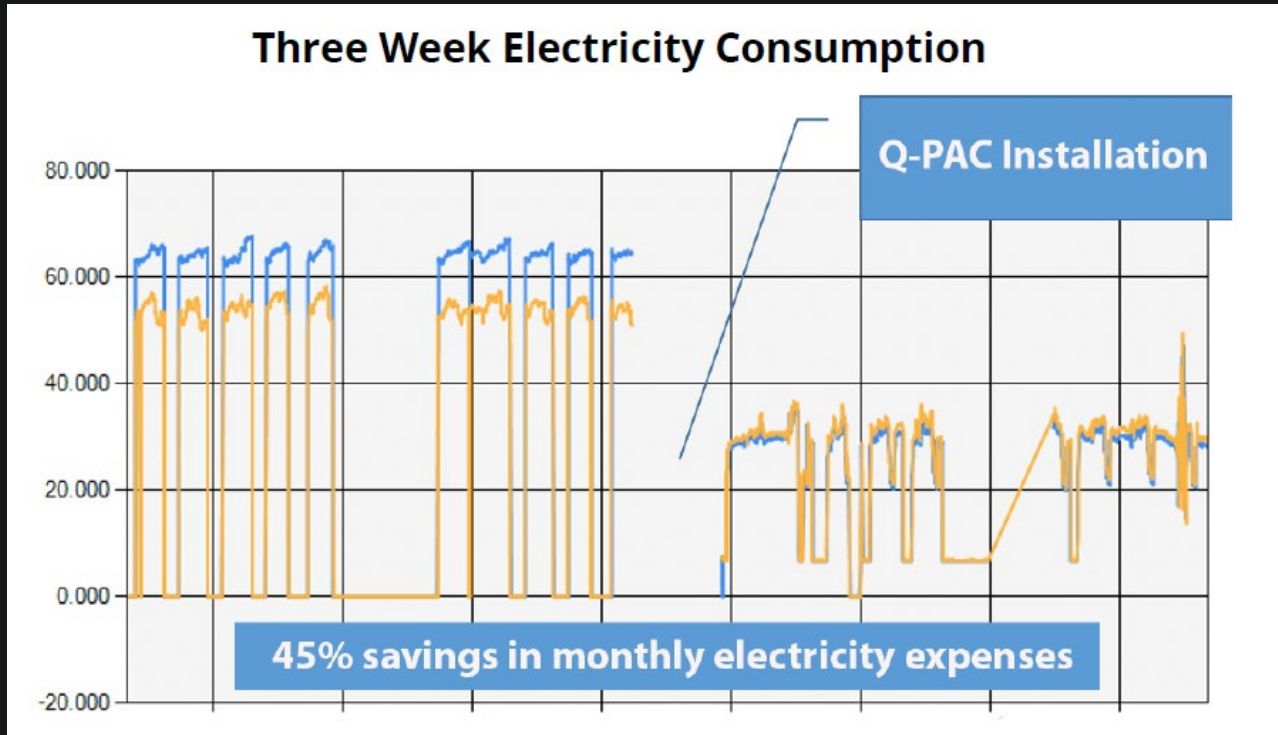

# Project Highlight: MOMA, NYC

Museum of Modern Arts, NYC

Tight Space

Low Vibration and Noise

Requirements

Commissioned in 2023



# Project Highlight: Regency Ballroom

- Regency Ballroom, San Francisco
- Major Mechanical Upgrades
- Historic 110-year-old Building
- Commissioned in 2024
- 50,000 CFM total fan replacement
- Winner of 2024/25 ASHRAE Region X Technology Award

Historic Fan and Boiler

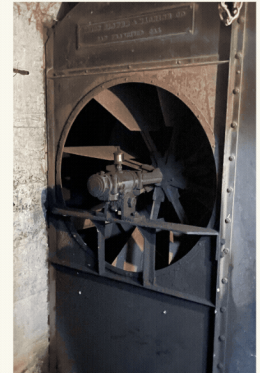
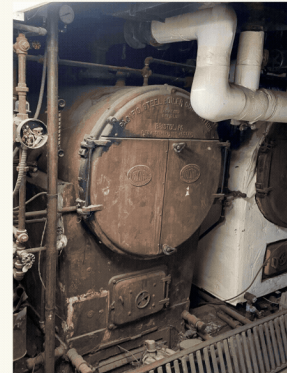

# Questions?

- Simple
- Easy to install
- Easy to operate
- Easy to maintain
- Redundant, resilient, and reliable

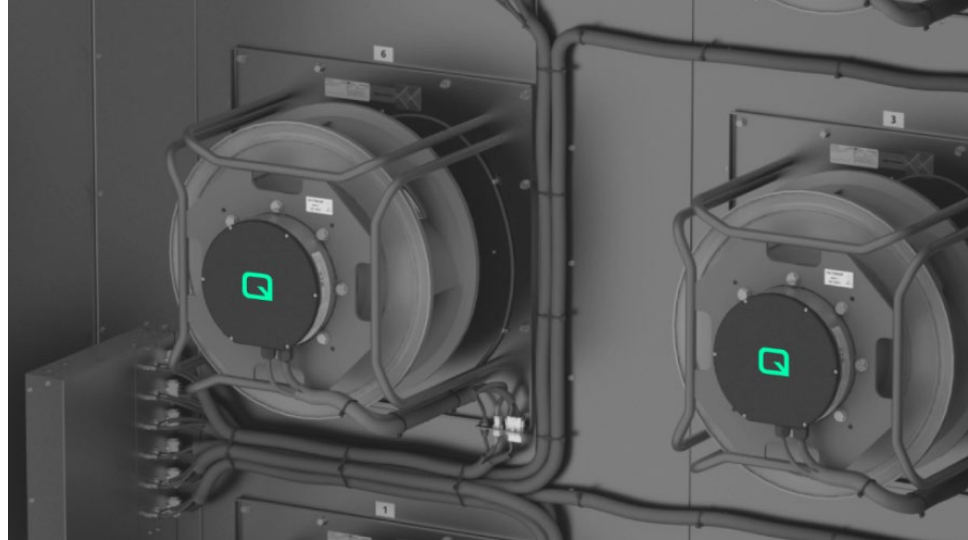

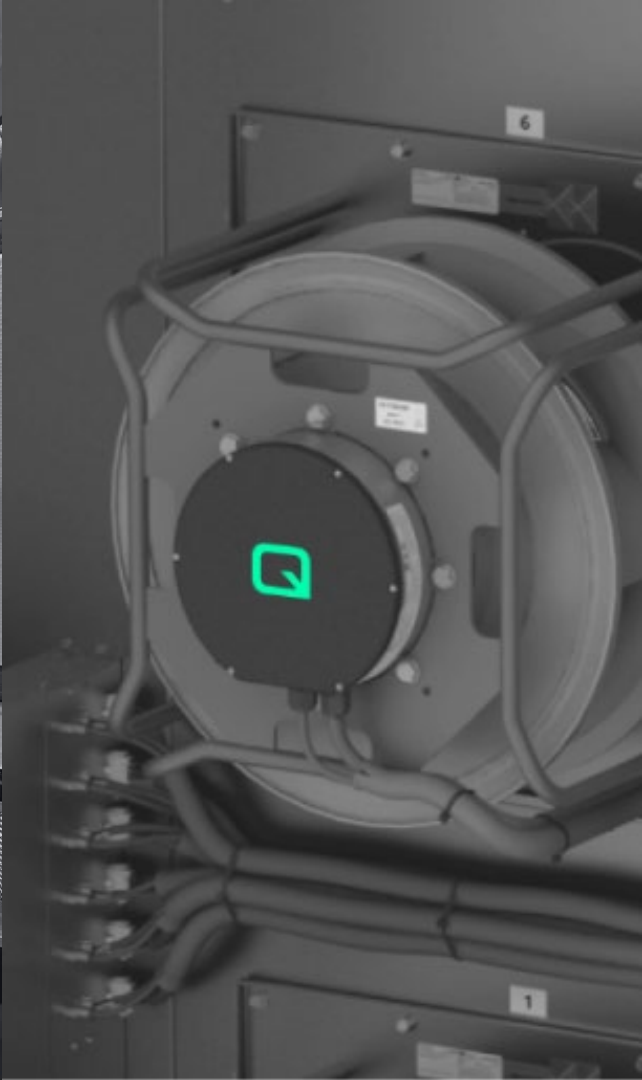

# Confidential

This document ("Presentation") constitutes the proprietary and confidential information of Q-PAC, Inc. ("Q-PAC"), and is protected by U.S. and international copyright law.

Thank you.

All rights reserved. You agree not to reproduce, retransmit, disseminate, sell, distribute, publish, broadcast, circulate or commercially exploit the Presentation in any manner without the express written consent of Q-PAC.